



# RPW Data Products

Ref: ROC-PRO-DAT-NTT-00006-LES  
Issue: 01  
Revision: 01  
Date: 17/11/2017

SOLAR ORBITER



# RPW Operation Centre

## RPW Data Products

ROC-PRO-DAT-NTT-00006-LES  
Iss.01, Rev.01

Prepared by:	Function:	Signature:	Date
Xavier Bonnin	RPW Ground Segment Project Manager		17/11/2017
Verified by:	Function:	Signature:	Date
RPW team	N/A		Dd/mm/yyyy
Approved by:	Function:	Signature:	Date
Milan Maksimovic	RPW PI		Dd/mm/yyyy
For application:	Function:	Signature:	Date
Name	Team Member #4		Dd/mm/yyyy

CLASSIFICATION

PUBLIC



RESTRICTED



CNRS-Observatoire de PARIS  
Section de MEUDON – LESIA  
5, place Jules Janssen  
92195 Meudon Cedex – France



## RPW Data Products

Ref: ROC-PRO-DAT-NTT-00006-LES

Issue: 01

Revision: 01

Date: 17/11/2017

- 2 / 40 -

### Change Record

Issue	Rev.	Date	Authors	Modifications
01	00	23/12/2016	X.Bonnin	First issue
01	01	17/11/2017	X.Bonnin	Introduced the following changes: <ul style="list-style-type: none"><li>• Add IDB_source meta-data in the LZ, L0, L1 and HK data</li><li>• Add PacketTime attribute in the LZ data</li><li>• Add sections about L1R, L3, L4 and ANC datasets</li><li>• Complete sections about L2 dataset</li><li>• Start the list of quicklook and L3 datasets</li><li>• Add list of CDF skeleton tables in the appendix</li></ul>
01	02		X.Bonnin	

### Acronym List

Acronym	Definition
ANC	Ancillary data
CDF	Common Data Format
CDPP	Centre de Données de Physique des Plasma
CWF	Continuous Waveform
DDS	Data Dissemination System
ESA	European Space Agency
ESAC	European Space Astronomy Centre
ESOC	European Space Operation Centre
GSE	Ground Support Equipment



## RPW Data Products

Ref: ROC-PRO-DAT-NTT-00006-LES

Issue: 01

Revision: 01

Date: 17/11/2017

- 3 / 40 -

HDF5	Hierarchical Data Format 5
HK	House Keeping
IACG	Inter-Agency Consultative Group
ICD	Interface Control Document
ID	Identifier
IDB	Instrument Database
ISTP	International Solar Terrestrial Physics
MADAWG	Modelling And Data Analysis Working Group
MOC	Mission Operation Centre
OBT	On-Board Time
PDF	Portable Document Format
PNG	Portable Network Graphics
RCS	RPW Calibration Software
ROC	RPW Operation Centre
RODP	ROC Operations and Data Pipeline
RPW	Radio and Plasma Waves instrument
RSWF	Regular Snapshot Waveform
SGS	Science Ground Segment
SOC	Science Operation Centre
SRDB	Spacecraft Reference Database
SWF	Snapshot Waveform
TC	Tele Command
TM	Telemetry
TBC	To Be Confirmed
TBD	To Be Determined
TBW	To Be Written
TSWF	Triggered Snapshot Waveform
UTC	Universal Time Coordinated
UUID	Universal Unique Identifier
WF	Waveform
XML	eXtended Markup Language



## Table of Contents

<b>1</b>	<b>General .....</b>	<b>7</b>
1.1	Scope of the Document .....	7
1.2	Applicable Documents .....	7
1.3	Reference Documents.....	7
1.4	Terminology.....	9
<b>2</b>	<b>RPW data formats, versioning and file naming.....</b>	<b>9</b>
2.1	RPW data processing level definition.....	9
2.2	RPW data formats .....	10
2.2.1	<i>RPW LZ data format .....</i>	<i>10</i>
2.2.2	<i>RPW L0 data format.....</i>	<i>10</i>
2.2.3	<i>RPW science L1 and L2 data format .....</i>	<i>11</i>
2.2.4	<i>RPW HK, L1R and CAL data format.....</i>	<i>11</i>
2.2.1	<i>RPW ANC data format .....</i>	<i>11</i>
2.2.2	<i>RPW quick-look format .....</i>	<i>11</i>
2.3	RPW data file naming convention .....	11
2.4	RPW data versioning convention .....	11
<b>3</b>	<b>RPW data sets .....</b>	<b>11</b>
3.1	General .....	12
3.1.1	<i>RPW data set concept &amp; definition.....</i>	<i>12</i>
3.1.2	<i>RPW data set identifier naming convention .....</i>	<i>12</i>
3.1	RPW Level zero (LZ) data set .....	12
3.1.1	<i>Data set overview.....</i>	<i>12</i>
3.1.2	<i>Data set organization .....</i>	<i>12</i>
3.1.3	<i>Data set nominal production cadence.....</i>	<i>15</i>
3.1.4	<i>Data set summary list.....</i>	<i>15</i>
3.2	RPW Level 0 (L0) data set.....	15
3.2.1	<i>Data set overview.....</i>	<i>15</i>
3.2.2	<i>Data set organization .....</i>	<i>15</i>
3.2.3	<i>Data set nominal production cadence.....</i>	<i>17</i>
3.2.4	<i>Data set summary list.....</i>	<i>18</i>
3.3	RPW Housekeeping (HK) data sets .....	18
3.3.1	<i>Data sets overview.....</i>	<i>18</i>
3.3.2	<i>Data sets organization .....</i>	<i>18</i>
3.3.3	<i>Data sets nominal production cadence .....</i>	<i>19</i>
3.3.4	<i>Data sets summary list.....</i>	<i>19</i>
3.4	RPW Level 1 (L1) science data sets .....	20
3.4.1	<i>Data sets overview.....</i>	<i>20</i>
3.4.2	<i>Data sets organization .....</i>	<i>20</i>
3.4.3	<i>Data sets nominal production cadence .....</i>	<i>20</i>
3.4.4	<i>Data sets summary list.....</i>	<i>20</i>
3.5	RPW Level 1R (L1R) science data sets .....	23
3.5.1	<i>Data sets overview.....</i>	<i>23</i>
3.5.2	<i>Data sets organization .....</i>	<i>23</i>
3.5.3	<i>Data sets nominal production cadence.....</i>	<i>25</i>
3.5.4	<i>Data sets summary list.....</i>	<i>25</i>
3.6	RPW Level 2 (L2) science data sets .....	26
3.6.1	<i>Data sets overview.....</i>	<i>26</i>
3.6.2	<i>Data sets organization .....</i>	<i>26</i>
3.6.3	<i>Data sets nominal production cadence .....</i>	<i>27</i>



# RPW Data Products

Ref: ROC-PRO-DAT-NTT-00006-LES

Issue: 01

Revision: 01

Date: 17/11/2017

- 5 / 40 -

- 3.6.4 *Data sets summary list*..... 28
- 3.7 RPW ancillary (ANC) data sets.....31
  - 3.7.1 *Time conversion data sets* ..... 31
  - 3.7.2 *Orbit/attitude/Frame data sets*..... 31
  - 3.7.3 *Effective antenna data sets*..... 31
- 3.8 RPW LL01 data sets.....31
  - 3.8.1 *Data sets overview*..... 31
  - 3.8.2 *Data sets organization* ..... 31
  - 3.8.3 *Data set nominal production cadence*..... 31
  - 3.8.4 *Data set summary list*..... 31
- 3.9 RPW quick-look data sets.....32
- 4 Other RPW data products..... 33**
  - 4.1 RPW Level 3 (L3) science data products.....33
    - 4.1.1 *RPW TNR-HFR specific L3 data products* ..... 33
    - 4.1.1 *RPW TDS specific L3 data products*..... 33
    - 4.1.2 *RPW LFR specific L3 data products* ..... 33
    - 4.1.3 *RPW SCM specific L3 data products* ..... 34
    - 4.1.4 *RPW Bias specific L3 data products* ..... 34
    - 4.1.5 *Other RPW L3 data products*..... 34
  - 4.2 RPW Level 4 (L4) science data products.....34
  - 4.3 RPW calibration table (RCT) files ..... 35
    - 4.3.1 *RCT data format*..... 35
    - 4.3.2 *RCT data versioning convention* ..... 35
    - 4.3.3 *RCT file naming convention* ..... 35
- 5 Appendix..... 35**
  - 5.1 XML schemas..... 35
    - 5.1.1 *RPW LZ data set XML schema*..... 35
  - 5.2 CDF skeleton tables schemas ..... 36
- 6 List of TBC/TBD/TBWs ..... 39**
- 7 Distribution list..... 40**



# RPW Data Products

Ref: ROC-PRO-DAT-NTT-00006-LES

Issue: 01

Revision: 01

Date: 17/11/2017

- 6 / 40 -

## List of tables

Table 1. RPW data processing levels.....	10
Table 2. LZ Header element fields.....	14
Table 3. LZ Data element fields.....	14
Table 4. LZ TmRaw element fields.....	14
Table 5. RPW LZ data sets.....	15
Table 6. RPW L0 data sets.....	18
Table 7. CDF metadata for HK datasets.....	19
Table 8. RPW HK data sets.....	20
Table 9. RPW L1 data sets.....	23
Table 10. L1R datasets expected items.....	24
Table 11. RPW L1R data sets.....	26
Table 12. RPW L2 data sets.....	31
Table 13. RPW LL01 data sets.....	32
Table 14. RPW quicklook datasets.....	33
Table 15. RPW TNR-HFR specific L3 data products.....	33
Table 16. RPW TDS specific L3 data products.....	33
Table 17. RPW LFR specific L3 data products.....	34
Table 18. RPW SCM specific L3 data products.....	34
Table 19. RPW Bias specific L3 data products.....	34
Table 20. Other RPW L3 data products.....	34

## List of figures

Figure 1. RPW L0 structure.....	17
---------------------------------	----



# RPW Data Products

Ref: ROC-PRO-DAT-NTT-00006-LES

Issue: 01

Revision: 01

Date: 17/11/2017

- 7 / 40 -

## 1 GENERAL

### 1.1 Scope of the Document

This document presents the RPW data products generated by the ROC Operations and Data Pipeline (RODP), including the RPW Calibration Software (RCS). The RODP will be the main data processing pipeline to be run by the RPW Operation Centre (ROC) [RD1] at the LESIA (Meudon, France) during the Solar Orbiter mission.

In the framework of this document, the RPW data definition includes the science data, but also the housekeeping parameters (HK), the ancillary (ANC) data and all their derived data such as quicklooks. Any other data relative to the instrument operations, monitoring, calibration, performance, and the ROC Ground Support Equipment (GSE) are not described in this document.

### 1.2 Applicable Documents

This document responds to the requirements of the documents listed in the following table:

Mark	Reference/Iss/Rev	Title of the document	Authors	Date
AD1	SOL-SGS-TN-00009/2/2	Metadata Definition for Solar Orbiter Science Data	Solar Orbiter MADA WG	23/07/2015
AD2	SOL-SGS-ICD-0004/1/4	Solar Orbiter Interface Control Document for Low Latency Data CDF Files	A.Walsh	07/11/2017
AD3	ROC-OPS-LLD-NTT-00028-LES/1/0	Dataset Description Document for RPW Low Latency CDF Files	X.Bonni n	09/02/2017
AD4	SOL-SGS-TN-0017-ANCDData/0/2	SOC-provided Ancillary Data for Solar Orbiter	A.Walsh	18/09/2017
AD5				

### 1.3 Reference Documents

This document is based on the documents listed in the following table:

Mark	Reference/Iss/Rev	Title of the document	Authors	Date
RD1	ROC-GEN-SYS-PLN-00002-LES/01/04	ROC Concept and Implementation Requirements Document (CIRD)	Y. De Conchy, X.Bonni n	17/11/2017
RD2	SOL-SGS-TN-0003/1/2	Solar Orbiter Low-Latency Data: Concept and Implementation	A. De Groof	19/09/2017
RD3	cdf36ifd.pdf	CDF Internal Format Description, V3.6.0	NASA/G SFC	02/02/2015
RD4	ROC-OPS-PIP-NTT-00008-LES/1/3	ROC Engineering Guidelines (REG)	X.Bonni n	17/11/2017
RD5	<a href="https://support.hdfgroup.org/HDF5/doc/UG/HDF5_Users_Guide-Responsive%20HTML5/index.html#t=HDF5_Users_Guide%2FHDF5_UG_Title%2FHDF5_UG_Title.htm">https://support.hdfgroup.org/HDF5/doc/UG/HDF5_Users_Guide-Responsive%20HTML5/index.html#t=HDF5_Users_Guide%2FHDF5_UG_Title%2FHDF5_UG_Title.htm</a>	HDF5 User's Guide	HDF5 group	March 2016



## RPW Data Products

Ref: ROC-PRO-DAT-NTT-00006-LES

Issue: 01

Revision: 01

Date: 17/11/2017

- 8 / 40 -

RD6	<a href="https://www.w3.org/TR/REC-xml/">https://www.w3.org/TR/REC-xml/</a>	Extensible Markup Language (XML) 1.0 (Fifth Edition)	W3C	26/11/2008
RD7	SOL-ESC-IF-05011/1/0	Solar Orbiter Data Delivery Interface Control Document	L. Michienzi	10/09/2013
RD8	EGOS-GEN-EDDS-EUICD/6/0	External user interface control document : EGOS Data Dissemination System (EDDS)	EDDS Team	28/05/2014
RD9	ROC-OPS-LLD-NTT-00028-LES/1/1	Dataset Description Document for RPW Low Latency CDF Files	X.Bonni n	06/03/2017
RD10	SOL.S.ASTR.RS.00061/4/0	Solar Orbiter Spacecraft SRDB Naming Convention & Population Rules	S.Brady	February 19, 2014
RD11	ROC-GEN-OTH-NTT-00036-LES/1/0	ROC Project Glossary of Terms	X.Bonni n	24/01/2017
RD12	<a href="https://naif.jpl.nasa.gov/naif/index.html">https://naif.jpl.nasa.gov/naif/index.html</a>	SPICE : An Observation Geometry System for Space Science Missions	NASA NAIF team	Sept. 2017
RD13	RPW-SYS-SSS-00013-LES/4/3	RPW Software System Specification (SSS)	P.Plasson	Dec. 12, 2016





## RPW Data Products

Ref: ROC-PRO-DAT-NTT-00006-LES

Issue: 01

Revision: 01

Date: 17/11/2017

- 9 / 40 -

### 1.4 Terminology

Except if it is explicitly mentioned, the definition of the terms listed in [RD11] is also applicable in this document.

## 2 RPW DATA FORMATS, VERSIONING AND FILE NAMING

### 2.1 RPW data processing level definition

The RPW data processing level definition shall follow the convention defined by the Solar Orbiter Science Operation Centre (SOC) in [AD1]. However, additional 'HK', 'LZ' and 'L1R' levels need to be introduced to cover all of the RPW data product categories.

The following table lists the data processing levels to be applied for the RPW data products. The additional levels (i.e., not defined in [AD1]) are indicated in *italic*.

Level	Description	Source	Users
<i>LZ</i>	Raw RPW telemetry (TM) as delivered by the Solar Orbiter Mission Operation Centre (MOC). ApID-separated, sorted, cleaned. Binary packet data encapsulated in XML files, as returned by the Data Dissemination System (DDS) of the MOC.  Daily XML format files.	MOC	ROC
L0	« Raw » data, unpacked and decompressed data  Daily HDF5 format files.	ROC	ROC
<i>HK</i>	Uncompressed and decommuted HK, engineering values, UTC-tagged.  Daily SOC-compliant CDFs, 1 file per sub-system.	ROC	ROC, RPW consortium
L1	Uncompressed and decommuted L0 + UTC-tagged, waveform and spectral data in telemetry units (uncalibrated) in spacecraft coordinate system. Data affinity group. E + B components in the same files.  Daily SOC-compliant CDFs, Quik Look and daily/orbital summary plots	ROC	ROC, RPW consortium, Solar Orbiter consortium, ESAC data archive centre, CDPP data archive centre
<i>L1R</i>	Same than L1, but including table index to link data with the associated calibration table.	ROC	ROC, RPW consortium
L2	L1 + waveform and spectral data in fully calibrated physical units [V, mV/m, nT, W/m <sup>2</sup> /Hz, nT <sup>2</sup> /Hz] in spacecraft and heliophysical coordinates systems. Separated E and B Waveform products.	ROC, using the RPW Calibration Software	ROC, RPW consortium, Solar Orbiter



# RPW Data Products

Ref: ROC-PRO-DAT-NTT-00006-LES

Issue: 01

Revision: 01

Date: 17/11/2017

- 10 / 40 -

	SOC-compliant CDFs, Quik Look and daily/orbital summary plots	(RCS)	consortium, ESAC data archive, CDDP data archive
L3	L2 + VxB removal for DC E-field measurement, offsets and corrections with data quality flags. Poynting flux. Plasma density. Spacecraft potential. Merged B. Merged density and temperature. Goniopolarimetry.  SOC-compliant CDFs, Science data plots.	RPW sub-systems teams	
L4	Event time tags and parameters		
CAL	Calibration data in CDFs	RCS teams	ROC, RPW consortium, ESAC data archive centre
ANC	Ancillary data (ANC) in SPICE kernels and CDFs	SOC	ROC, RPW consortium CDDP data archive (TBC)
LL01	LL engineering data, output of the LL pipeline  Specific CDF format files [AD3]	SOC (from RPW Low Latency Data Pipeline) ROC (backup instance)	SOC, ROC, IT
LL02	Operational LL data, enhanced with S/C HK  Specific CDF format files [AD2]	SOC	SOC, ROC, Solar Orbiter consortium
LL03	Visualisation of operational LL data, in “quicklook” format Data in PNG or JPG2000 (TBC)	SOC	SOC, ROC, Solar Orbiter consortium

Table 1. RPW data processing levels.

## 2.2 RPW data formats

### 2.2.1 RPW LZ data format

The RPW LZ data shall be written into XML V1.0 [RD6] format files.

### 2.2.2 RPW L0 data format

The RPW L0 data shall be written into HDF5 [RD5] format files.



### 2.2.3 RPW science L1 and L2 data format

According to [AD1], all of the RPW science L1 and L2 data shall be saved in NASA Common Data Format (CDF) files [RD3].

### 2.2.4 RPW HK, L1R and CAL data format

All of the RPW HK, L1R and CAL data files produced by the ROC shall be saved in the NASA CDF.

### 2.2.1 RPW ANC data format

The SOC will deliver to Solar Orbiter-related ANC data, i.e., orbit/attitude/time conversion, in both SPICE kernels [RD12] and CDF files to the Instrument Teams (IT), as described in [AD4].

The ROC does not plan to generate ANC data proper to RPW at this stage of the project. Nevertheless, the centre shall retrieve and distribute to the RPW consortium, both the SOC ANC SPICE kernel and CDF data files.

### 2.2.2 RPW quick-look format

The primary format to produce the RPW quicklooks shall be the Portable Document Format (PDF).

## 2.3 RPW data file naming convention

The file naming convention for the LZ, L0, L1, L2, L3, CAL, ANC and HK shall follow the SOC definition [AD1].

The LL01, LL02 and LL03 data files shall follow the specific naming convention defined in [AD2].

There is no generic convention for other data products.

## 2.4 RPW data versioning convention

The data versioning for the LZ, L0, L1, L2, L3, CAL, ANC and HK shall follow the SOC convention [AD1].

It means that the first version of a given data file shall always be “01”. Then, the data version number shall be incremented by 1, each time this file shall be re-processed due to a change inside.

Note that this rule only concerns data files that have been already distributed publicly through the Solar Orbiter data archive centres (i.e., ESAC, CDPP). Especially, the data version of the preliminary calibrated science data (i.e., L1R, L2, L3) might often change before delivery and should not be updated prior to the archiving.

The LL01, LL02 and LL03 data shall follow the specific data versioning convention defined in [AD2].

## 3 RPW DATA SETS

This section presents the RPW datasets to be processed by the ROC pipelines. The detailed content of the CDF format file dataset can be viewed in the skeleton tables (see the list of files in the appendix).



## 3.1 General

### 3.1.1 RPW data set concept & definition

The traceability of the RPW data produced by the ROC pipelines is ensured using the concept of *RPW data set*. It is a specific category of data products that is uniquely referenced into the ROC pipelines.

A RPW data set shall:

- Be generated by the ROC pipelines, or any software called by the latter (e.g., RPW L2 data generated by the RPW Calibration Software, RCS)
- Be uniquely identified in the ROC pipelines, using a dedicated dataset identifier (hereafter also called RPW DS ID)
- Follow the conventions defined in the section 2.

A data product that does follow the rules above cannot be considered as a data set, and cannot be hence identified and processed by the ROC pipelines.

### 3.1.2 RPW data set identifier naming convention

Each RPW data set shall be identified with a unique uppercase string of the following form:

[Source\_name]\_[Level]\_[Descriptor]

Where [Source\_name], [Level] and [Descriptor] are respectively the source of data (it shall always be “SOLO” for the data generated on-board during the mission), the RPW data processing level as defined in the section 2.1, and the data descriptor.

The data descriptor is a string that shall be explicit enough to uniquely identify the data set. It must: (i) contain only alphanumerical characters, (ii) use only the hyphen “-“ as separator, (iii) always start with the string “RPW”.

In the case where the data set is associated to a single RPW sub-system, the data descriptor shall always start with the prefix “RPW-*[sub-system]*”, where *[sub-system]* can be “PDU”, “DPU”, “DAS”, “DBS”, “THR”, “TNR”, “HFR”, “TDS”, “LFR” or “BIA”.

Note that the value of the data source, level and descriptor shall be the same than the [Source\_name], [Level] and [Descriptor] prefix values of the CDF global attributes, as defined in [AD1].

## 3.1 RPW Level zero (LZ) data set

### 3.1.1 Data set overview

There is only one RPW LZ data set containing the RPW TM raw binary packets, as returned by the Solar Orbiter Data Dissemination System (DDS) [RD7].

### 3.1.2 Data set organization

The RPW LZ data files shall be written in the XML format. The XML schema (.xsd) is visible in the section 5.1.1.

The tables below give the description of the expected structure. The first column (**Field**) provides the name of the element (tag value) or attribute as seen in the resulting XML file. The second column (**E/A**) indicates whether the field is an XML element (using ‘E’), or an attribute (using ‘A’) of an XML element. The third column (**Type**), describes the basic type



## RPW Data Products

Ref: ROC-PRO-DAT-NTT-00006-LES

Issue: 01

Revision: 01

Date: 17/11/2017

- 13 / 40 -

of the field. The fourth field (**Description**) provides a textual definition of the field which may contain examples, format specifications and conditional statements about what the field may contain. The final column (**Need**) indicates whether the field's value is Mandatory (M), Optional (O), or Qualified (Q) – the latter requiring explanation in the Description column.

### 3.1.2.1 Header

Field	E/A	Type	Description	Need
Project	E	string	see "Project" CDF global attribute definition in [AD1].	M
Source_name	E	string	see "Source_name" CDF global attribute definition in [AD1].	M
Descriptor	E	string	see "Descriptor" CDF global attribute definition in [AD1].	M
Level	E	string	Data processing level. It must be "LZ"	M
StartTime	E	dateTime	Creation date/time of the first packet in the file (in RPW on-board time reference)	M
EndTime	E	dateTime	Creation date/time of the last packet in the file (in RPW on-board time reference)	M
Generation_date	E	dateTime	Local date/time of the LZ file creation	M
Data_version	E	integer	Data version	M
Software_name	E	string	Name of the software that has created the file	M
Software_version	E	string	Version of the software that has created the file	M
Pipeline_name	E	string	Name of the ROC pipeline that has created the file. It must be "RODP".	M
Pipeline_version	E	string	Version of the ROC pipeline that has created the file	M
File_ID	E	string	Unique ID of the file. (Generated by the software when the file was created)	M
Dataset_ID	E	string	RPW dataset ID for LZ in the ROC system. It must be	M



# RPW Data Products

Ref: ROC-PRO-DAT-NTT-00006-LES

Issue: 01

Revision: 01

Date: 17/11/2017

- 14 / 40 -

Field	E/A	Type	Description	Need
Provider	E	string	Provider of the file. It must be "ROC".	M
IDB_version	E	string	Version of the RPW Instrument Database (IDB) associated with the TM packets written in the file.	M
IDB_Source	E	string	Source of the RPW IDB ("PALISADE" or "MIB"; in production, it shall always be "MIB")	

Table 2. LZ Header element fields.

### 3.1.2.2 Data

Field	E/A	Type	Description	Need
TmRaw	E	ComplexType	Complex type containing the list of RPW TM packets	M

Table 3. LZ Data element fields.

The TmRaw ComplexType must contain the following fields.

Field	E/A	Type	Description	Need
Packet	E	hexBinary	A TM raw packet in hexadecimal	M
PacketID	A	long	ID of the packet as written in the DDS XML file	M
Status	A	string	Status of the packet. It can be "Validated" or "Corrupted"	M
Name	A	string	Human-readable name of the TM. Only required if the value of Status is "Validated"	Q
SrdbID	A	string	ID of the TM in SRDB. Only required if the value of Status is "Validated"	Q
PacketTime	A	dateTime	Date and time of the packet generation on-board	Q

Table 4. LZ TmRaw element fields.



# RPW Data Products

Ref: ROC-PRO-DAT-NTT-00006-LES

Issue: 01

Revision: 01

Date: 17/11/2017

- 15 / 40 -

### 3.1.3 Data set nominal production cadence

A single daily LZ data file is produced by the ROC in the nominal case. This file contains the entire RPW TM packet data acquired by the instrument for this day.

### 3.1.4 Data set summary list

RPW DS ID	Description	Data format file	Production cadence	Parent dataset RPW DS ID
SOLO_LZ_RPW	RPW TM binary data, packeted and compressed, as sent by the DDS	XML format	Daily	N/A

Table 5. RPW LZ data sets.

## 3.2 RPW Level 0 (L0) data set

### 3.2.1 Data set overview

There is only one RPW L0 data set. It contains the decompressed/de-commutated RPW TM packet data, after analysis of the LZ file content using the RPW Instrument Database (IDB). Note that at this level only the raw values, not engineering, are stored in the file. Especially the source data blocks in the science TM packets are not fully parsed yet.

### 3.2.2 Data set organization

The RPW L0 data files shall be written in the HDF5 format. Figure 1 shows the structure of the file content, which is composed of:

- **/root**, the top-level HDF5 file group, which contains the following mandatory attributes:
  - **Project**, same definition than for LZ data set (section 3.1.2.1)
  - **Source\_name**, same definition than for LZ data set (section 3.1.2.1)
  - **Level**, the data processing level. It must be “L0”.
  - **Descriptor**, same definition than for LZ data set (section 3.1.2.1)
  - **Data\_version**, same definition than for LZ data set (section 3.1.2.1)
  - **Dataset\_ID**, same definition than for LZ data set (section 3.1.2.1). It shall be “SOLO\_L0\_RPW”
  - **File\_ID**, same definition than for LZ data set (section 3.1.2.1)
  - **Generation\_date**, same definition than for LZ data set (section 3.1.2.1)
  - **Software\_name**, same definition than for LZ data set (section 3.1.2.1)
  - **Software\_version**, same definition than for LZ data set (section 3.1.2.1)
  - **Pipeline\_name**, same definition than for LZ data set (section 3.1.2.1). It shall be “RODP”
  - **Pipeline\_version**, same definition than for LZ data set (section 3.1.2.1)
  - **IDB\_version**, same definition than for LZ data set (section 3.1.2.1).
  - **IDB\_source**, same definition than for LZ data set (section 3.1.2.1).
- **/TM**, the HDF5 group storing the RPW TM packet data as:



## RPW Data Products

Ref: ROC-PRO-DAT-NTT-00006-LES

Issue: 01

Revision: 01

Date: 17/11/2017

- 16 / 40 -

- ***[/TM\_PACKET\_#i]***, a series of /TM HDF5 groups named as the RPW PALISADE IDB naming convention for the RPW TM packets (e.g “TM\_DPU\_BIA\_HK”, “TM\_TDS\_SCIENCE\_LFM\_CWF”, etc.). There is one group per RPW packet ID, which contains:
  - **PACKET\_SRDB\_ID**, a mandatory attribute providing the SRDB ID of the TM packet [RD10].
  - **/packet\_header**, a HDF5 group storing the TM packet header parameters into HDF5 datasets:
    - ***[/Packet\_header\_parameter\_#i]***, a series of dataset named as the RPW IDB ID naming convention for the RPW TM PACKET\_HEADER parameters (e.g “CCSDS\_VERSION\_NUMBER”, “PACKET\_TYPE”, etc.). There is one dataset per packet parameter ID name, which contains an [n, m] array, where n is the number of *[/TM\_PACKET\_#i]* packets in the current file, and m is the number of *[/Packet\_data\_field\_header\_parameter\_#i]* parameter values for a given packet. In practice the packet header parameters have a single scalar value per packet (i.e., m=1).
  - **/data\_field\_header**, a HDF5 group storing the TM packet data field header parameters into HDF5 datasets:
    - ***[/Packet\_data\_field\_header\_parameter\_#i]***, a series of dataset named as the RPW IDB ID naming convention for the RPW TM DATA\_FIELD\_HEADER parameters (e.g “DESTINATION\_ID”, “SERVICE\_TYPE”, etc.). There is one dataset per packet parameter ID name, which contains an [n, m] array, where n is the number of *[/TM\_PACKET\_#i]* packets in the current file, and m is the number of *[/Packet\_data\_field\_header\_parameter\_#i]* parameter values for a given packet. In practice the data field header parameters have a single scalar value per packet (i.e., m=1).
  - **/source\_data**, a HDF5 group storing the TM packet source data parameters into HDF5 datasets:
    - ***[/Packet\_source\_data\_parameter\_#i]***, a series of dataset named as the RPW IDB ID naming convention for the RPW TM SOURCE\_DATA parameters (e.g “PA\_TDS\_ACQUISITION\_TIME”, “PA\_BIA\_ON\_OFF”, etc.). There is one dataset per packet parameter ID, which contains:
      - **PARAM\_SRDB\_ID**, a mandatory attribute providing the SRDB ID of the TM packet parameter [RD10].
      - **ENUM\_SRDB\_ID**, an optional dataset attribute providing the SRDB ID of the enumeration [RD10], when it exists.





- **TF\_SRDB\_ID**, an optional dataset attribute providing the SRDB ID of the transfer function [RD10], when it exists.
- **PARAM\_MIN**, an optional dataset attribute providing the minimal value of the parameter, when it exists.
- **PARAM\_MAX**, an optional dataset attribute providing the maximal value of the parameter, when it exists.
- **PARAM\_DEF**, an optional dataset attribute providing the default value of the parameter, when it exists.
- An  $[n, m]$  array, where  $n$  is the number of  $[TM\_PACKET\_#i]$  packets in the current file, and  $m$  the number of parameter values for the  $[Packet\_source\_data\_parameter\_#i]$  parameter in a given packet.

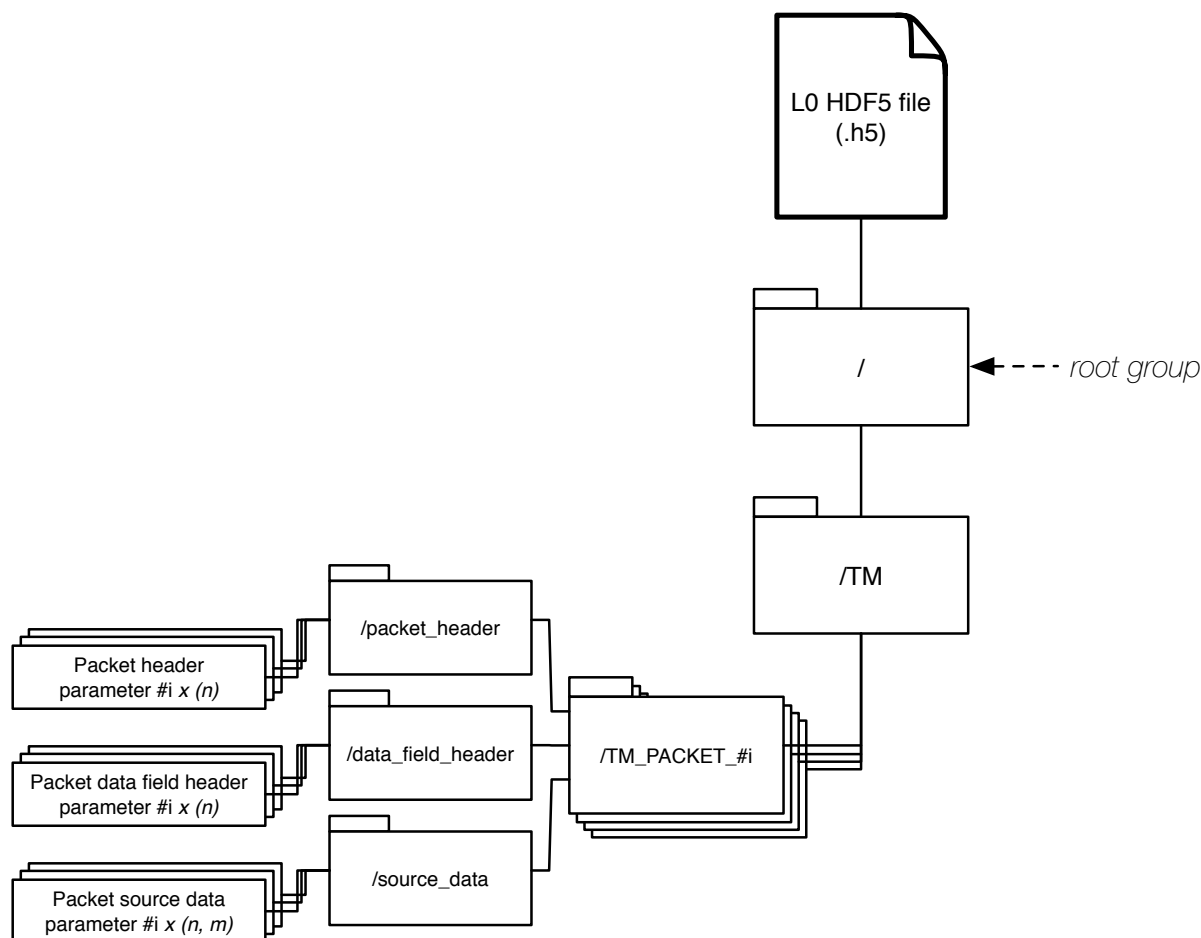

Figure 1. RPW L0 structure.

### 3.2.3 Data set nominal production cadence

A single daily L0 data file is produced by the ROC in the nominal case. This file contains the entire RPW TM packet data acquired by the instrument for this day, after decompression/decommutation. In practice the L0 file is generated from the parent LZ file.



# RPW Data Products

Ref: ROC-PRO-DAT-NTT-00006-LES

Issue: 01

Revision: 01

Date: 17/11/2017

- 18 / 40 -

## 3.2.4 Data set summary list

RPW DS ID	Description	Data file format	Production cadence	Parent dataset RPW DS ID
SOLO_L0_RPW	RPW TM data, unpacked and uncompressed, after analysis of the corresponding LZ data file with the IDB	HDF5	Daily	SOLO_LZ_RPW

Table 6. RPW L0 data sets.

## 3.3 RPW Housekeeping (HK) data sets

### 3.3.1 Data sets overview

The HK level data sets store the RPW TM packets of the Housekeeping reporting category.

### 3.3.2 Data sets organization

The data and metadata definition of the HK data sets shall comply the SOC conventions for CDF [AD1].

Additionally, the following attributes must be found in the files.

Attribute name	Attribute type	CDF data type	Description	Need
PACKET_CATEGORY	Global	CDF_CHAR	RPW TM packet category as defined in [RD13]	M
PACKET_PID	Global	CDF_CHAR	RPW TM packet process ID	M
PACKET_SERVICE_SUBTYPE	Global	CDF_CHAR	RPW TM packet service subtype	M
PACKET_SERVICE_TYPE	Global	CDF_CHAR	RPW TM packet service type	M
PACKET_SID	Global	CDF_CHAR	RPW TM packet source ID	M
PACKET_SRDB_ID	Global	CDF_CHAR	RPW TM packet SRDB ID	M
APPLICABLE	Global	CDF_CHAR	Reference to the applicable document. It shall be the current one (i.e., "ROC-	M



# RPW Data Products

Ref: ROC-PRO-DAT-NTT-00006-LES

Issue: 01

Revision: 01

Date: 17/11/2017

- 19 / 40 -

			PRO-DAT-NTT-00006-LES”)	
SKELETON_PARENT	Global	CDF_CHAR	Name of the skeleton file used to generate the current file, without the extension.	M
SRDB_ENUM_ID	Variable	CDF_CHAR	SRDB ID of the associated enumeration	Q (only if the parameter is associated with an enumeration list)
SRDB_PARAM_ID	Variable	CDF_CHAR	SRDB ID of the parameter in the packet	Q (only if the zVariable is a packet parameter with a valid SRDB ID)

**Table 7. CDF metadata for HK datasets.**

There must be a single CDF zVariable per HK parameter inside the file, and one CDF record per HK packet.

### 3.3.3 Data sets nominal production cadence

There is a single daily HK file produced for each RPW sub-system.

Note that in the case of the on-demand “TM\_\*\_PARAMETER\_DUMP” packets, distinct files are generated containing all of the packets for the day.

The HK files for a given day are processed from the analysis of the parent L0 daily file.

### 3.3.4 Data sets summary list

RPW DS ID	Description	Data file format	Production Cadence	Parent data set RPW DS ID
SOLO_HK_RPW-DBS	Contains HK parameters from the TM_DPU_DBS_HK packets	CDF	Daily	SOLO_L0_RPW
SOLO_HK_RPW-DAS	Contains HK parameters from the TM_DPU_DAS_HK packets	CDF	Daily	SOLO_L0_RPW
SOLO_HK_RPW-DAS-STATISTICS	Contains HK parameters from the TM_DPU_DAS_STATISTICS_HK packets	CDF	Daily	SOLO_L0_RPW
SOLO_HK_RPW-TDS	Contains HK parameters from the TM_TDS_HK packets	CDF	Daily	SOLO_L0_RPW
SOLO_HK_RPW-LFR	Contains HK parameters from the TM_LFR_HK packets	CDF	Daily	SOLO_L0_RPW
SOLO_HK_RPW-THR	Contains HK parameters from the TM_THR_HK packets	CDF	Daily	SOLO_L0_RPW
SOLO_HK_RPW-BIA	Contains HK parameters from the TM_DPU_BIA_HK packets	CDF	Daily	SOLO_L0_RPW



# RPW Data Products

Ref: ROC-PRO-DAT-NTT-00006-LES

Issue: 01

Revision: 01

Date: 17/11/2017

- 20 / 40 -

SOLO_HK_RPW-PDU	Contains HK parameters from the TM_DPU_PDU_HK packets	CDF	Daily	SOLO_L0_RPW
SOLO_HK-RPW-DBS-DUMP	Contains HK parameters from the TM_DPU_PDU_HK packets	CDF	Daily	SOLO_L0_RPW
SOLO_HK-RPW-DBS-DUMP	Contains HK parameters from the TM_DPU_DBS_PARAMETER_DUMP packets	CDF	Daily	SOLO_L0_RPW
SOLO_HK-RPW-DAS-DUMP	Contains HK parameters from the TM_DPU_DAS_PARAMETER_DUMP packets	CDF	Daily	SOLO_L0_RPW
SOLO_HK-RPW-TDS-DUMP	Contains HK parameters from the TM_TDS_PARAMETER_DUMP packets	CDF	Daily	SOLO_L0_RPW
SOLO_HK-RPW-LFR-DUMP	Contains HK parameters from the TM_LFR_PARAMETER_DUMP packets	CDF	Daily	SOLO_L0_RPW
SOLO_HK-RPW-THR-DUMP	Contains HK parameters from the TM_THR_PARAMETER_DUMP packets	CDF	Daily	SOLO_L0_RPW

Table 8. RPW HK data sets.

## 3.4 RPW Level 1 (L1) science data sets

### 3.4.1 Data sets overview

The L1 science data sets stores the RPW science TM packet data, but organized by instrument receiver (TNR, HFR, TDS, LFR), modes (SURV, LFM<sup>1</sup>, SBM1, SBM2) and data affinity (spectra, waveforms, etc.)

### 3.4.2 Data sets organization

The data and metadata definition of the L1 science data sets shall comply the SOC conventions for CDF [AD1].

Additionally, the attributes listed in the Table 7 must be found.

### 3.4.3 Data sets nominal production cadence

The L1 data files are daily produced from the analysis of the parent L0 daily file, except the SOLO\_L1\_RPW-BIA-SWEEP data set, which is generated each time a Bias sweeping is performed on-board, and the datasets related to the SBM1 and SBM2 modes, for which a single file per event must be created. In the latter case, a time interval must be thus given in the file name.

### 3.4.4 Data sets summary list

RPW DS ID	Description	Data file format	Production Cadence	Parent data set RPW DS ID
SOLO_L1_RPW-TNR-SURV	Contains RPW TNR L1 spectral data in normal and burst survey mode, time-tagged	CDF	Daily	SOLO_L0_RPW
SOLO_L1_RPW-HFR-SURV	Contains RPW HFR L1 spectral data in	CDF	Daily	SOLO_L0_RPW

<sup>1</sup> Only for TDS



## RPW Data Products

Ref: ROC-PRO-DAT-NTT-00006-LES

Issue: 01

Revision: 01

Date: 17/11/2017

- 21 / 40 -

	normal and burst survey mode, time-tagged			
SOLO_L1_RPW-TDS-SURV-RSWF	Contains RPW TDS L1 regular snapshot waveform data in normal and burst survey mode, time-tagged	CDF	Daily	SOLO_L0_RPW
SOLO_L1_RPW-TDS-SURV-TSWF	Contains RPW TDS L1 triggered snapshot waveform data in normal and burst survey mode, time-tagged	CDF	Daily	SOLO_L0_RPW
SOLO_L1_RPW-TDS-SURV-HIST1D	Contains RPW TDS L1 1D histogram data in normal and burst survey mode, time-tagged	CDF	Daily	SOLO_L0_RPW
SOLO_L1_RPW-TDS-SURV-HIST2D	Contains RPW TDS L1 2D histogram data in normal and burst survey mode, time-tagged	CDF	Daily	SOLO_L0_RPW
SOLO_L1_RPW-TDS-SURV-STAT	Contains RPW TDS L1 statistical data in normal and burst survey mode, time-tagged	CDF	Daily	SOLO_L0_RPW
SOLO_L1_RPW-TDS-SURV-MAMP	Contains RPW TDS L1 continuous HF signal maximum data in normal and burst survey mode, time-tagged	CDF	Daily	SOLO_L0_RPW
SOLO_L1_RPW-TDS-LFM-RSWF	Contains RPW TDS L1 regular snapshot waveform data in low frequency mode, time-tagged	CDF	Daily	SOLO_L0_RPW
SOLO_L1_RPW-TDS-LFM-CWF	Contains RPW TDS L1 continuous waveform data in low frequency mode, time-tagged	CDF	Daily	SOLO_L0_RPW
SOLO_L1_RPW-TDS-LFM-SM	Contains RPW TDS L1 spectral matrix data in low frequency mode, time-tagged	CDF	Daily	SOLO_L0_RPW
SOLO_L1_RPW-TDS-LFM-PSD	Contains RPW TDS L1 single power spectrum data in low frequency mode, time-tagged	CDF	Daily	SOLO_L0_RPW
SOLO_L1_RPW-TDS-SBM1-	Contains RPW TDS L1 regular snapshot	CDF	One single file per SBM1	SOLO_L0_RPW



## RPW Data Products

Ref: ROC-PRO-DAT-NTT-00006-LES

Issue: 01

Revision: 01

Date: 17/11/2017

- 22 / 40 -

RSWF	waveform data in SBM1 mode, time-tagged		event. In this case, the event time range is provided in the filename.	
SOLO_L1_RPW-TDS-SBM2-TSWF	Contains RPW TDS L1 triggered snapshot waveform data in SBM2 mode, time-tagged	CDF	One single file per SBM2 event. In this case, the event time range is provided in the filename.	SOLO_L0_RPW
SOLO_L1_RPW-LFR-SURV-ASM	Contains RPW LFR L1 averaged spectral matrix data in normal and burst survey mode, time-tagged	CDF	Daily	SOLO_L0_RPW
SOLO_L1_RPW-LFR-SURV-BP1	Contains RPW LFR L1 basic parameters 1 data in normal and burst survey mode, time-tagged	CDF	Daily	SOLO_L0_RPW
SOLO_L1_RPW-LFR-SURV-BP2	Contains RPW LFR L1 basic parameters 2 data in normal and burst survey mode, time-tagged	CDF	Daily	SOLO_L0_RPW
SOLO_L1_RPW-LFR-SURV-CWF	Contains RPW LFR L1 continuous waveform data in normal and burst survey mode, time-tagged	CDF	Daily	SOLO_L0_RPW
SOLO_L1_RPW-LFR-SURV-SWF	Contains RPW LFR L1 snapshot waveform data in normal and burst survey mode, time-tagged	CDF	Daily	SOLO_L0_RPW
SOLO_L1_RPW-LFR-SBM1-CWF	Contains RPW LFR L1 continuous waveform data in SBM1 mode, time-tagged	CDF	One single file per SBM1 event. In this case, the event time range is provided in the filename.	SOLO_L0_RPW
SOLO_L1_RPW-LFR-SBM1-BP1	Contains RPW LFR L1 basic parameters 1 data in SBM1 mode, time-tagged	CDF	One single file per SBM1 event. In this case, the event time range is provided in the filename.	SOLO_L0_RPW



# RPW Data Products

Ref: ROC-PRO-DAT-NTT-00006-LES

Issue: 01

Revision: 01

Date: 17/11/2017

- 23 / 40 -

SOLO_L1_RPW-LFR-SBM1-BP2	Contains RPW LFR L1 basic parameters 2 data in SBM1 mode, time-tagged	CDF	One single file per SBM1 event. In this case, the event time range is provided in the filename.	SOLO_L0_RPW
SOLO_L1_RPW-LFR-SBM2-CWF	Contains RPW LFR L1 continuous waveform data in SBM2 mode, time-tagged	CDF	One single file per SBM2 event. In this case, the event time range is provided in the filename.	SOLO_L0_RPW
SOLO_L1_RPW-LFR-SBM2-BP1	Contains RPW LFR L1 basic parameters 1 data in SBM2 mode, time-tagged	CDF	One single file per SBM2 event. In this case, the event time range is provided in the filename.	SOLO_L0_RPW
SOLO_L1_RPW-LFR-SBM2-BP2	Contains RPW LFR L1 basic parameters 2 data in SBM2 mode, time-tagged	CDF	One single file per SBM2 event. In this case, the event time range is provided in the filename.	SOLO_L0_RPW
SOLO_L1_RPW-BIA-SWEEP	Contains RPW BIAS L1 parameters from a given sweeping	CDF	One single file per Bias sweeping. In this case, the sweeping time range is provided in the filename.	SOLO_LL01_RPW-BIA + the CP_DPU_BIA_SWEEP_STEP_CUR Bias current step values from the TC_DPU_LOAD_BIAS_SWEEP (ZIW00060), used when performing the Bias sweeping

Table 9. RPW L1 data sets.

## 3.5 RPW Level 1R (L1R) science data sets

### 3.5.1 Data sets overview

The L1R level data sets only concern the LFR/TDS waveform (WF) data (snapshot and continuous). They provide L1 data plus additional parameters, which allow the Bias and SCM RCS to generate the corresponding L2 data sets.

The L1R intermediary datasets will be for internal purpose only, and thus should be not distributed to teams outside the RPW consortium.

### 3.5.2 Data sets organization

The L1R data sets structure is the same than the L1 parent data set, except that:



## RPW Data Products

Ref: ROC-PRO-DAT-NTT-00006-LES

Issue: 01

Revision: 01

Date: 17/11/2017

- 24 / 40 -

- The electrical (E) and magnetic (B) components WF data must be delivered in separated files. It means that only zVariables related to the E/B components must be found on the E/B L1R data files
- Specific attributes and zVariables listed in the Table 10 must be added depending of the L1R datasets.
- The L1R must be delivered with up-to-date calibration table files (see section 4.3 for more details). These files are required to generate L2 data files.

In addition to the L1 attributes and zVariables, the L1R files shall contain the following extra items.

Name	Type	Description	Comment
CAL_ENTITY_NAME	Global attribute (CDF_CHAR)	Entity in charge of the calibration (person or team)	There must as many as entries than the number of calibration table files associated to the L1R file.
CAL_ENTITY_AFFILIATION	Global attribute (CDF_CHAR)	Affiliation of the entity in charge of the calibration	There must as many as entries than the number of calibration table files associated to the L1R file.
CAL_EQUIPMENT	Global attribute (CDF_CHAR)	RPW equipment associated to the calibration table. The values can be: "LFR", "TDS" or "THR"	There must as many as entries than the number of calibration table files associated to the L1R file.
CALIBRATION_TABLE	Global attribute (CDF_CHAR)	Filename of the calibration table(s).	There must as many as entries than the number of calibration table files associated to the L1R file.
CALIBRATION_TABLE_INDEX	zVariable (CDF_UINT1)	Index of the calibration table(s) value required to generate L2 data files.	Each CDF record shall contain 2 elements: the first element shall gives the index of the associated CALIBRATION_TABLE entry (i.e., 0 for the first entry, 1 for the second, etc.). The second element shall refer to the index of the value to be used inside the calibration table file.
CALIBRATION_VERSION	Global attribute (CDF_CHAR)	Version of the calibration table.	There must as many as entries than the number of calibration table files associated to the L1R file.

**Table 10. L1R datasets extra items.**





## RPW Data Products

Ref: ROC-PRO-DAT-NTT-00006-LES

Issue: 01

Revision: 01

Date: 17/11/2017

- 25 / 40 -

### 3.5.3 Data sets nominal production cadence

The L1R data files are generated from the analysis of the parent L1 files, which means with the same production cadence.

### 3.5.4 Data sets summary list

RPW DS ID	Description	Data file format	Production Cadence	Parent data set RPW DS ID
SOLO_L1R_RPW-TDS-SURV-RSWF-E	Contains RPW TDS L1R RSWF science electric data in survey mode, time-tagged	CDF	Daily	SOLO_L1_RPW-TDS-SURV-RSWF
SOLO_L1R_RPW-TDS-SURV-RSWF-B	Contains RPW TDS L1R RSWF science magnetic data in survey mode, time-tagged	CDF	Daily	SOLO_L1_RPW-TDS-SURV-RSWF
SOLO_L1R_RPW-TDS-SURV-TSWF-E	Contains RPW TDS L1R TSWF science electric data in survey mode, time-tagged	CDF	Daily	SOLO_L1_RPW-TDS-SURV-TSWF
SOLO_L1R_RPW-TDS-SURV-TSWF-B	Contains RPW TDS L1R TSWF magnetic electric data in survey mode, time-tagged	CDF	Daily	SOLO_L1_RPW-TDS-SURV-TSWF
SOLO_L1R_RPW-TDS-LFM-RSWF-E	Contains RPW TDS L1R RSWF electrical science data in LFM mode, time-tagged	CDF	Daily	SOLO_L1_RPW-TDS-LFM-RSWF
SOLO_L1R_RPW-TDS-LFM-RSWF-B	Contains RPW TDS L1R RSWF magnetic science data in LFM mode, time-tagged	CDF	Daily	SOLO_L1_RPW-TDS-LFM-RSWF
SOLO_L1R_RPW-TDS-LFM-CWF-E	Contains RPW TDS L1R CWF electrical science data in LFM mode, time-tagged	CDF	Daily	SOLO_L1_RPW-TDS-LFM-CWF
SOLO_L1R_RPW-TDS-LFM-CWF-B	Contains RPW TDS L1R CWF magnetic science data in LFM mode, time-tagged	CDF	Daily	SOLO_L1_RPW-TDS-LFM-CWF
SOLO_L1R_RPW-TDS-SBM1-RSWF-E	Contains RPW TDS L1R RSWF science electric data in SBM1 mode, time-tagged	CDF	One single file per SBM1 event. In this case, the event time range is provided in the filename.	SOLO_L1_RPW-TDS-SBM1-RSWF
SOLO_L1R_RPW-TDS-SBM1-RSWF-B	Contains RPW TDS L1R RSWF science magnetic data in SBM1 mode, time-tagged	CDF	One single file per SBM1 event. In this case, the event time range is provided in the filename.	SOLO_L1_RPW-TDS-SBM1-RSWF
SOLO_L1R_RPW-TDS-SBM2-TSWF-E	Contains RPW TDS L1R TSWF science electric data in SBM2 mode, time-tagged	CDF	One single file per SBM2 event. In this case, the event time range is provided in the filename.	SOLO_L1_RPW-TDS-SBM2-TSWF



# RPW Data Products

Ref: ROC-PRO-DAT-NTT-00006-LES

Issue: 01

Revision: 01

Date: 17/11/2017

- 26 / 40 -

SOLO_L1R_RPW-TDS-SBM2-TSWF-B	Contains RPW TDS L1R TSWF science magnetic data in SBM2 mode, time-tagged	CDF	One single file per SBM2 event. In this case, the event time range is provided in the filename.	SOLO_L1_RPW-TDS-SBM2-TSWF
SOLO_L1R_RPW-LFR-SURV-CWF-E	Contains RPW LFR L1R CWF electrical science data in survey mode, time-tagged	CDF	Daily	SOLO_L1_RPW-LFR-SURV-CWF
SOLO_L1R_RPW-LFR-SURV-CWF-B	Contains RPW LFR L1R CWF magnetic science data in survey mode, time-tagged	CDF	Daily	SOLO_L1_RPW-LFR-SURV-CWF
SOLO_L1R_RPW-LFR-SURV-SWF-E	Contains RPW LFR L1R SWF electrical science data in survey mode, time-tagged	CDF	Daily	SOLO_L1_RPW-LFR-SURV-SWF
SOLO_L1R_RPW-LFR-SURV-SWF-B	Contains RPW LFR L1R SWF magnetic science data in survey mode, time-tagged	CDF	Daily	SOLO_L1_RPW-LFR-SURV-SWF
SOLO_L1R_RPW-LFR-SBM1-CWF-E	Contains RPW LFR L1R CWF electrical science data in SBM1 mode, time-tagged	CDF	One single file per SBM1 event. In this case, the event time range is provided in the filename.	SOLO_L1_RPW-LFR-SBM1-CWF
SOLO_L1R_RPW-LFR-SBM1-CWF-B	Contains RPW LFR L1R CWF magnetic science data in SBM1 mode, time-tagged	CDF	One single file per SBM1 event. In this case, the event time range is provided in the filename.	SOLO_L1_RPW-LFR-SBM1-CWF
SOLO_L1R_RPW-LFR-SBM2-CWF-E	Contains RPW LFR L1R CWF electrical science data in SBM2 mode, time-tagged	CDF	One single file per SBM2 event. In this case, the event time range is provided in the filename.	SOLO_L1_RPW-LFR-SBM2-CWF
SOLO_L1R_RPW-LFR-SBM2-CWF-B	Contains RPW LFR L1R CWF magnetic science data in SBM2 mode, time-tagged	CDF	One single file per SBM2 event. In this case, the event time range is provided in the filename.	SOLO_L1_RPW-LFR-SBM2-CWF

Table 11. RPW L1R data sets.

## 3.6 RPW Level 2 (L2) science data sets

### 3.6.1 Data sets overview

The L2 level data sets store the RPW calibrated science data files produced by the RCS from the un-calibrated data files (L1 or L1R).

### 3.6.2 Data sets organization

The structure of the L2 datasets is the same than the parent L1/L1R datasets, except that:



# RPW Data Products

Ref: ROC-PRO-DAT-NTT-00006-LES

Issue: 01

Revision: 01

Date: 17/11/2017

- 27 / 40 -

- The following zVariables shall not be found: SCET, ACQUISITION\_TIME
- The following global attributes shall not be found: PACKET\_CATEGORY (global), PACKET\_SRDB\_ID, PACKET\_SERVICE\_TYPE, PACKET\_SERVICE\_SUBTYPE, PACKET\_SID and PACKET\_PID
- The following variable attributes shall not be found: SRDB\_ENUM\_ID, SRDB\_PARAM\_ID
- The attributes and zVariables listed in the Table 12 shall be found.
- The SOLO\_L2\_RPW-TDS-LFM-PSDSM dataset is generated from the SOLO\_L1\_RPW-TDS-LFM-PDS and SOLO\_L1\_RPW-TDS-LFM-SM datasets respectively

In addition to the expected L2 attributes and zVariables, the L2 files shall contain the following extra items.

Name	Type	Description	Comment
CAL_ENTITY_NAME	Global attribute (CDF_CHAR)	Entity in charge of the calibration (person or team)	There must as many as entries than the number of calibration table files associated to the L2 file.
CAL_ENTITY_AFFILIATION	Global attribute (CDF_CHAR)	Affiliation of the entity in charge of the calibration	There must as many as entries than the number of calibration table files associated to the L2 file.
CAL_EQUIPMENT	Global attribute (CDF_CHAR)	RPW equipment associated to the calibration table. The values can be: "SCM", "ANT", "PA_HF", "BIAS", "LFR", "TDS" or "THR"	There must as many as entries than the number of calibration table files associated to the L2 file.
CALIBRATION_TABLE	Global attribute (CDF_CHAR)	Filename of the calibration table(s).	There must as many as entries than the number of calibration table files associated to the L2 file.
CALIBRATION_VERSION	Global attribute (CDF_CHAR)	Version of the calibration table.	There must as many as entries than the number of calibration table files associated to the L2 file.

Table 12. L2 datasets extra items.

### 3.6.3 Data sets nominal production cadence

There is one-to-one production of a L2 data file from a given L1/L1R file, except that the SOLO\_L2\_RPW-TDS-LFM-PSDSM dataset is generated from the SOLO\_L1\_RPW-TDS-LFM-PDS and SOLO\_L1\_RPW-TDS-LFM-SM datasets respectively.



# RPW Data Products

Ref: ROC-PRO-DAT-NTT-00006-LES

Issue: 01

Revision: 01

Date: 17/11/2017

- 28 / 40 -

## 3.6.4 Data sets summary list

RPW DS ID	Description	Data file format	Production Cadence	Parent data set RPW DS ID
SOLO_L2_RPW-TNR-SURV	Contains RPW TNR L2 spectral data in normal and burst survey mode, time-tagged	CDF	Daily	SOLO_L1_RPW-TNR-SURV
SOLO_L2_RPW-HFR-SURV	Contains RPW HFR L2 spectral data in normal and burst survey mode, time-tagged	CDF	Daily	SOLO_L1_RPW-HFR-SURV
SOLO_L2_RPW-TDS-SURV-RSWF-E	Contains RPW TDS L2 regular snapshot waveform data – electrical components - in normal and burst survey mode, time-tagged	CDF	Daily	SOLO_L1R_RPW-TDS-SURV-RSWF-E
SOLO_L2_RPW-TDS-SURV-RSWF-B	Contains RPW TDS L2 regular snapshot waveform data – magnetic components - in normal and burst survey mode, time-tagged	CDF	Daily	SOLO_L1R_RPW-TDS-SURV-RSWF-B
SOLO_L2_RPW-TDS-SURV-TSWF-E	Contains RPW TDS L2 triggered snapshot waveform data – electrical components - in normal and burst survey mode, time-tagged	CDF	Daily	SOLO_L1R_RPW-TDS-SURV-TSWF-E
SOLO_L2_RPW-TDS-SURV-TSWF-B	Contains RPW TDS L2 triggered snapshot waveform data – magnetic components - in normal and burst survey mode, time-tagged	CDF	Daily	SOLO_L1R_RPW-TDS-SURV-TSWF-B
SOLO_L2_RPW-TDS-SURV-HIST1D	Contains RPW TDS L2 1D histogram data in normal and burst survey mode, time-tagged	CDF	Daily	SOLO_L1_RPW-TDS-SURV-HIST1D
SOLO_L2_RPW-TDS-SURV-HIST2D	Contains RPW TDS L2 2D histogram data in normal and burst survey mode, time-tagged	CDF	Daily	SOLO_L1_RPW-TDS-SURV-HIST2D
SOLO_L2_RPW-TDS-SURV-STAT	Contains RPW TDS L2 statistical data in normal and burst survey mode, time-tagged	CDF	Daily	SOLO_L1_RPW-TDS-SURV-STAT
SOLO_L2_RPW-TDS-SURV-MAMP	Contains RPW TDS L2 continous HF signal maximum data in normal and burst survey mode, time-tagged	CDF	Daily	SOLO_L1_RPW-TDS-SURV-MAMP
SOLO_L2_RPW-TDS-LFM-RSWF-E	Contains RPW TDS L2 regular snapshot waveform data – electrical components - in low frequency mode, time-tagged	CDF	Daily	SOLO_L1R_RPW-TDS-LFM-RSWF-E



## RPW Data Products

Ref: ROC-PRO-DAT-NTT-00006-LES

Issue: 01

Revision: 01

Date: 17/11/2017

- 29 / 40 -

SOLO_L2_RPW-TDS-LFM-RSWF-B	Contains RPW TDS L2 regular snapshot waveform data – magnetic components - in low frequency mode, time-tagged	CDF	Daily	SOLO_L1R_RPW-TDS-LFM-RSWF-B
SOLO_L2_RPW-TDS-LFM-CWF-E	Contains RPW TDS L2 continuous waveform data – electric components - in low frequency mode, time-tagged	CDF	Daily	SOLO_L1R_RPW-TDS-LFM-CWF-E
SOLO_L2_RPW-TDS-LFM-CWF-B	Contains RPW TDS L2 continuous waveform data – magnetic components - in low frequency mode, time-tagged	CDF	Daily	SOLO_L1R_RPW-TDS-LFM-CWF-B
SOLO_L2_RPW-TDS-LFM-PSDSM	Contains RPW TDS L2 single power spectrum and spectral matrix data in low frequency mode, time-tagged	CDF	Daily	SOLO_L1_RPW-TDS-LFM-PSD SOLO_L1_RPW-TDS-LFM-SM
SOLO_L2_RPW-TDS-SBM1-RSWF-E	Contains RPW TDS L2 regular snapshot waveform data – electrical compenents - in SBM1 mode, time-tagged	CDF	One single file per SBM1 event. In this case, the event time range is provided in the filename.	SOLO_L1R_RPW-TDS-SBM1-RSWF-E
SOLO_L2_RPW-TDS-SBM1-RSWF-B	Contains RPW TDS L2 regular snapshot waveform data – magnetic compenents - in SBM1 mode, time-tagged	CDF	One single file per SBM1 event. In this case, the event time range is provided in the filename.	SOLO_L1R_RPW-TDS-SBM1-RSWF-B
SOLO_L2_RPW-TDS-SBM2-TSWF-E	Contains RPW TDS L2 triggered snapshot waveform data – electrical components- in SBM2 mode, time-tagged	CDF	One single file per SBM2 event. In this case, the event time range is provided in the filename.	SOLO_L1R_RPW-TDS-SBM2-TSWF-E
SOLO_L2_RPW-TDS-SBM2-TSWF-B	Contains RPW TDS L2 triggered snapshot waveform data – magnetic components - in SBM2 mode, time-tagged	CDF	One single file per SBM2 event. In this case, the event time range is provided in the filename.	SOLO_L1R_RPW-TDS-SBM2-TSWF-B
SOLO_L2_RPW-LFR-SURV-ASM	Contains RPW LFR L2 averaged spectral matrix data in normal and burst survey mode, time-tagged	CDF	Daily	SOLO_L1_RPW-LFR-SURV-ASM
SOLO_L2_RPW-LFR-SURV-BP1	Contains RPW LFR L2 basic parameters 1 data in normal and burst survey mode, time-tagged	CDF	Daily	SOLO_L1_RPW-LFR-SURV-BP1
SOLO_L2_RPW-LFR-SURV-BP2	Contains RPW LFR L2 basic parameters 2 data in normal and burst survey mode, time-tagged	CDF	Daily	SOLO_L1_RPW-LFR-SURV-BP2
SOLO_L2_RPW-	Contains RPW LFR L2	CDF	Daily	SOLO_L1R_RPW-



## RPW Data Products

**Ref: ROC-PRO-DAT-NTT-00006-LES**

**Issue: 01**

**Revision: 01**

**Date: 17/11/2017**

- 30 / 40 -

LFR-SURV-CWF-E	continuous waveform data – electrical components - in normal and burst survey mode, time-tagged			LFR-SURV-CWF-E
SOLO_L2_RPW-LFR-SURV-CWF-B	Contains RPW LFR L2 continuous waveform data – magnetic components - in normal and burst survey mode, time-tagged	CDF	Daily	SOLO_L1R_RPW-LFR-SURV-CWF-B
SOLO_L2_RPW-LFR-SURV-SWF	Contains RPW LFR L2 snapshot waveform data in normal and burst survey mode, time-tagged	CDF	Daily	SOLO_L1R_RPW-LFR-SURV-SWF-E
SOLO_L2_RPW-LFR-SURV-SWF-B	Contains RPW LFR L2 snapshot waveform data – magnetic components - in normal and burst survey mode, time-tagged	CDF	Daily	SOLO_L1R_RPW-LFR-SURV-SWF-E
SOLO_L2_RPW-LFR-SBM1-CWF - E	Contains RPW LFR L2 continuous waveform data - electrical components - in SBM1 mode, time-tagged	CDF	One single file per SBM1 event. In this case, the event time range is provided in the filename.	SOLO_L1R_RPW-LFR-SBM1-CWF-E
SOLO_L2_RPW-LFR-SBM1-CWF - B	Contains RPW LFR L2 continuous waveform data – magnetic components - in SBM1 mode, time-tagged	CDF	One single file per SBM1 event. In this case, the event time range is provided in the filename.	SOLO_L1R_RPW-LFR-SBM1-CWF-B
SOLO_L2_RPW-LFR-SBM1-BP1	Contains RPW LFR L2 basic parameters 1 data in SBM1 mode, time-tagged	CDF	One single file per SBM1 event. In this case, the event time range is provided in the filename.	SOLO_L1_RPW-LFR-SBM1-BP1
SOLO_L2_RPW-LFR-SBM1-BP2	Contains RPW LFR L2 basic parameters 2 data in SBM1 mode, time-tagged	CDF	One single file per SBM1 event. In this case, the event time range is provided in the filename.	SOLO_L1_RPW-LFR-SBM1-BP2
SOLO_L2_RPW-LFR-SBM2-CWF-E	Contains RPW LFR L2 continuous waveform data - electrical components - in SBM2 mode, time-tagged	CDF	One single file per SBM2 event. In this case, the event time range is provided in the filename.	SOLO_L1R_RPW-LFR-SBM2-CWF-E
SOLO_L2_RPW-LFR-SBM2-CWF - B	Contains RPW LFR L2 continuous waveform data – magnetic components - in SBM2 mode, time-tagged	CDF	One single file per SBM2 event. In this case, the event time range is provided in the filename.	SOLO_L1R_RPW-LFR-SBM2-CWF-B
SOLO_L2_RPW-LFR-SBM2-BP1	Contains RPW LFR L2 basic parameters 1 data in SBM2 mode, time-tagged	CDF	One single file per SBM2 event. In this case, the event time range is	SOLO_L1_RPW-LFR-SBM2-BP1



# RPW Data Products

Ref: ROC-PRO-DAT-NTT-00006-LES

Issue: 01

Revision: 01

Date: 17/11/2017

- 31 / 40 -

			provided in the filename.	
SOLO_L2_RPW-LFR-SBM2-BP2	Contains RPW LFR L2 basic parameters 2 data in SBM2 mode, time-tagged	CDF	One single file per SBM2 event. In this case, the event time range is provided in the filename.	SOLO_L1_RPW-LFR-SBM2-BP2

Table 13. RPW L2 data sets.

## 3.7 RPW ancillary (ANC) data sets

### 3.7.1 Time conversion data sets

There is no specific RPW dataset for the on-board time (OBT)-UTC time conversion. The ROC will use the SPICE kernels produced and delivered by the SOC [AD4].

### 3.7.2 Orbit/attitude/Frame data sets

There is no specific RPW dataset for the orbit/attitude/frame data sets. The ROC will use the SPICE kernels produced and delivered by the SOC [AD4].

Additionally, the ROC plans to retrieve and share the SOC ancillary data in the CDF format.

### 3.7.3 Effective antenna data sets

The ROC may plan to produce a specific “ck” SPICE kernel, which contain RPW effective antennas vectors. The exact content of this kernel and the way to generate it is **TBD**.

## 3.8 RPW LL01 data sets

### 3.8.1 Data sets overview

The RPW Low Latency level 1 (LL01) data sets contain the TM packets downlinked from the dedicated on-board LL packet store. The LL TM packets for RPW are listed in [RD9].

### 3.8.2 Data sets organization

The LL01 data set structure is described in details in [RD9].

### 3.8.3 Data set nominal production cadence

The LL01 data production cadence is defined in [RD9].

### 3.8.4 Data set summary list

RPW DS ID	Description	Data file format	Production Cadence	Parent data set RPW DS ID
SOLO_LL01_RPW-TNR	Contains the RPW LL01 data from TNR-HFR LL packets	CDF	As soon as new LZ files are available	ROC_LZ_RPW
SOLO_LL01_RPW-BIA	Contains the RPW LL01 data from the LFR LL packets for BIAS calibrations	CDF	As soon as new LZ files are available	ROC_LZ_RPW
SOLO_LL01_RPW-SBM1	Contains the RPW LL01 data from the SBM1 LL packets	CDF	As soon as new LZ files are available	ROC_LZ_RPW
SOLO_LL01_RPW-SBM2	Contains the RPW LL01 data from the	CDF	As soon as new LZ files are available	ROC_LZ_RPW



# RPW Data Products

Ref: ROC-PRO-DAT-NTT-00006-LES

Issue: 01

Revision: 01

Date: 17/11/2017

- 32 / 40 -

	SBM2 LL packets			
--	-----------------	--	--	--

Table 14. RPW LL01 data sets.

## 3.9 RPW quick-look data sets

The table below gives an overview of the RPW quicklook datasets, which are expected to be directly produced by the RODP. This section does not concern L3 derived data products as defined in [AD4].

This list is not exhaustive, and is susceptible to be extended. Especially, the L2/L3-related summary plots, units and graphical details to be found in the quicklooks are not fully defined at this stage of the project.

RPW DS ID	Description	Data file format	Production Cadence	Parent data set RPW DS ID
SOLO_L1_RPW-THR-SURV	Daily plots of the TNR-HFR dynamic spectra (Intensity in Db as a function of MHz and UTC)	PDF	Daily	SOLO_L1_RPW-TNR-SURV and SOLO_L1_RPW-HFR-SURV
SOLO_L1_TDS-SURV-CWF	TDS daily CWF amplitude in dB as a function of time for each of the channel	PDF	Daily	SOLO_L1_TDS-SURV-CWF
SOLO_L1_RPW-TDS-SURV-SWF	TDS daily RSWF/TSWF as a function of time for each of the channel (one snapshot per file)	PDF	One snapshot per file	SOLO_L1_RPW-TDS-SURV-RSWF
SOLO_L1_RPW-LFR-SURV-CWF	LFR daily CWF as a function of time for each of the channel	PDF	Daily	SOLO_L1_RPW-LFR-SURV-CWF
SOLO_L1_RPW-LFR-SURV-ASM	LFR daily ASM data	PDF	Daily	SOLO_L1_RPW-LFR-SURV-ASM
SOLO_L1_RPW-LFR-SURV-BP1	LFR daily BP1 data	PDF	Daily	SOLO_L1_RPW-LFR-SURV-BP1
SOLO_L1_RPW-LFR-SURV-BP2	LFR daily BP2 data	PDF	Daily	SOLO_L1_RPW-LFR-SURV-BP2
SOLO_L1_RPW-LFR-SURV-SWF	LFR daily SWF as a function of time for each of the channel	PDF	One snapshot per file	SOLO_L1_LFR-SURV-SWF
SOLO_L1_RPW-SBM1-EVENT	Summary plots gathering the TDS/LFR SBM1 data. Details to be defined.	PDF	One file per SBM1 event	SOLO_L1_RPW-LFR-SBM1-* SOLO_L1_RPW-TDS-SBM1-* SOLO_LL01_RPW-SBM1
SOLO_L1_RPW-SBM2-EVENT	Summary plots gathering the THR/TDS/LFR SBM2 data. Details to be defined.	PDF	One file per SBM2 event	SOLO_L1_RPW-LFR-SBM2-* SOLO_L1_RPW-TDS-SBM2-* SOLO_L1_RPW-TNR-SURV SOLO_LL01_RPW-SBM2





# RPW Data Products

Ref: ROC-PRO-DAT-NTT-00006-LES

Issue: 01

Revision: 01

Date: 17/11/2017

- 33 / 40 -

SOLO_L1_RPW-BIA-SWEEP	Plots a given Bias sweeping (I vs V)	PDF	One bias sweeping per file	SOLO_LL01_RPW-BIA SOLO_L01_RPW-BIA-SWEEP
SOLO_SP-LL01_RPW-SBM1-MAG-SWA (TBC)	Plots LL01 data from MAG, SWA and RPW for SBM1 event detection	PDF	Daily	SOLO_LL01_RPW-SBM1 TBD
SOLO_SP-LL01_RPW-SBM2-MAG-SWA (TBC)	Plots LL01 data from MAG, SWA and RPW for SBM2 event detection	PDF	Daily	SOLO_LL01_RPW-SBM2 TBD

Table 15. RPW quicklook datasets.

## 4 OTHER RPW DATA PRODUCTS

### 4.1 RPW Level 3 (L3) science data products

The ROC does not plan to generate the science data products at L3 level with the RODP, and thus they are not considered as RPW datasets. Nevertheless, L3 data files are expected to be archived at and distribute using the ROC infrastructure.

The following sections give the list of L3 data files, which are planned to be produced during the mission.

#### 4.1.1 RPW TNR-HFR specific L3 data products

The TNR-HFR team plans to produce the L3 data in the table below. For convenience, the first column gives the name of L3 data product, using the same convention than RPW data set.

L3 data product	Description	Data file format	Production Cadence	Parent data set RPW DS ID
SOLO_L3_RPW-TNR-GPi	Contains the RPW L3 goniopolarimetry parameters from TNR data, using the “i” inversion algo.	CDF	Daily	ROC_L2_RPW-TNR-SURV

Table 16. RPW TNR-HFR specific L3 data products.

#### 4.1.1 RPW TDS specific L3 data products

The TDS team plans to produce the L3 data in the table below. For convenience, the first column gives the name of L3 data product, using the same convention than RPW data set.

L3 data product	Description	Data file format	Production Cadence	Parent data set RPW DS ID

Table 17. RPW TDS specific L3 data products.

#### 4.1.2 RPW LFR specific L3 data products

The LFR team plans to produce the L3 data in the table below. For convenience, the first column gives the name of L3 data product, using the same convention than RPW data set.



# RPW Data Products

Ref: ROC-PRO-DAT-NTT-00006-LES

Issue: 01

Revision: 01

Date: 17/11/2017

L3 data product	Description	Data file format	Production Cadence	Parent data set RPW DS ID

Table 18. RPW LFR specific L3 data products.

### 4.1.3 RPW SCM specific L3 data products

The SCM team plans to produce the L3 data in the table below. For convenience, the first column gives the name of L3 data product, using the same convention than RPW data set.

L3 data product	Description	Data file format	Production Cadence	Parent data set RPW DS ID

Table 19. RPW SCM specific L3 data products.

### 4.1.4 RPW Bias specific L3 data products

The Bias team plans to produce the L3 data in the table below. For convenience, the first column gives the name of L3 data product, using the same convention than RPW data set.

L3 data product	Description	Data file format	Production Cadence	Parent data set RPW DS ID
SOLO_L3_RPW-BIA-ExB	ExB drift	CDF		
SOLO_L3_RPW-BIA-SC-POT	True S/C potential	CDF		
SOLO_L3_RPW-BIA-3D-E-FIELD	3D electrical field (E dot B = 0)			

Table 20. RPW Bias specific L3 data products.

### 4.1.5 Other RPW L3 data products

The table below lists all other L3 data products for RPW. For convenience, the first column gives the name of L3 data product, using the same convention than RPW data set.

L3 data product	Description	Data file format	Production Cadence	Parent data set RPW DS ID

Table 21. Other RPW L3 data products.

## 4.2 RPW Level 4 (L4) science data products

The science data products at L4 level are not generated by the RODP, and thus are not considered as RPW datasets. Nevertheless, a part of L4 data may be archived at and distribute using the ROC infrastructure.

The list of expected L4 data products are not yet defined at this stage of the project.



## 4.3 RPW calibration table (RCT) files

The L1R datasets are delivered with so-called “RPW calibration tables” (RCT), which are files containing information to convert un-calibrated L1 science data into calibrated data at receiver level (i.e., typically gains and phases for each receiver configuration as a function of the frequency and temperature).

### 4.3.1 RCT data format

The RCT files must be written using the CDF format.

### 4.3.2 RCT data versioning convention

The version of the RCT CDF data file must be the local date and time of creation of the file, in the format: “YYYYMMDDHHNN”, where “YYYY”, “MM”, “DD”, “HH” and “NN” are respectively the 4-digits year, 2-digits month, 2-digits day, 2-digits hours, 2-digits minutes of the file creation.

In the RCT filename, the version number must appear with the “V” prefix (e.g., “V202210122359”).

### 4.3.3 RCT file naming convention

The RCT shall comply the following file naming convention:

SOLO\_CAL\_RPW-[receiver]\_[free-field]\_[Version].cdf

Where [receiver] is the name of the receiver in uppercase characters (i.e., “TDS” pr “LFR”) of the corresponding RPW L1R data set, [free-field] is a field that can be used to specify the content of the file (e.g., “BIAS-F0”) and [Version] is the version of the calibration table file (see previous section).

Note that this RCT naming convention is not fully compliant with the SOC definition [AD1]. It is envisaged to gather the RCT for a given period of time - time when the RCT values have not changed (**TBC**) – into a single file, which complies SOC specification. This file will have to be delivered for the Solar Orbiter data archive.

## 5 APPENDIX

### 5.1 XML schemas

#### 5.1.1 RPW LZ data set XML schema

```
<xml version "1.0" encoding "UTF-8" >
<xsd:schema xmlns:xsd "http://www.w3.org/2001/XMLSchema">
  <xsd:element name "RpwLz">
    <xsd:complexType>
      <xsd:sequence>
        <xsd:element name "Header" type "HeaderType"/>
        <xsd:element name "Data" type "DataType"/>
      </xsd:sequence>
    </xsd:complexType>
  </xsd:element>

  <xsd:complexType name "HeaderType">
    <xsd:sequence>
      <xsd:element name "Project" type "xsd:string"/>
      <xsd:element name "Source_name" type "xsd:string"/>
      <xsd:element name "Descriptor" type "xsd:string" />
      <xsd:element name "StartTime" type "xsd:dateTime" />
    </xsd:sequence>
  </xsd:complexType>
</xsd:schema>
```



```
<xsd:element name "EndTime" type "xsd:dateTime" />
<xsd:element name "Level" type "xsd:string" />
<xsd:element name "Generation_date" type "xsd:dateTime" />
<xsd:element name "Data_version" type "xsd:integer" />
<xsd:element name "Software_name" type "xsd:string"></xsd:element>
<xsd:element name "Software_version" type "xsd:string" />
<xsd:element name "Pipeline_name" type "xsd:string"></xsd:element>
<xsd:element name "Pipeline_version" type "xsd:string" />
<xsd:element name "File_UUID" type "xsd:string" />
<xsd:element name "Dataset_ID" type "xsd:string" />
<xsd:element name "Provider" type "xsd:string"></xsd:element>
<xsd:element name "IDB_version" type "xsd:string"></xsd:element>
</xsd:sequence>
</xsd:complexType>

<xsd:complexType name "DataType">
<xsd:sequence>
<xsd:element name "TmRaw" type "TmRawType" minOccurs "1"/>
</xsd:sequence>
</xsd:complexType>

<xsd:complexType name "TmRawType">
<xsd:sequence>
<xsd:element name "Packet" type "xsd:hexBinary" minOccurs "1"/>
</xsd:sequence>
<xsd:attribute name "PacketID" type "xsd:long" use "required"
></xsd:attribute>
<xsd:attribute name "Status" type "xsd:string"
use "required"></xsd:attribute>
<xsd:attribute name "Name" type "xsd:string" use "optional"></xsd:attribute>
<xsd:attribute name "SrdID" type "xsd:string"
use "optional"></xsd:attribute>
</xsd:complexType>
</xsd:schema>
```

## 5.2 CDF skeleton tables schemas

The tree below gives the list of CDF skeleton table files.

Note that the SOLO\_HK\_CDF-TEMPLATE\_V01.skt file is a template use by the ROC pipeline to generate the HK digest CDF files from the RPW Instrument Database in an automated way.

Skeleton/

- |— SOLO\_HK\_CDF-TEMPLATE\_V01.skt
- |— SOLO\_HK\_RPW-BIA\_V01.skt
- |— SOLO\_HK\_RPW-DAS-STATISTICS\_V01.skt
- |— SOLO\_HK\_RPW-DAS\_V01.skt
- |— SOLO\_HK\_RPW-DBS\_V01.skt
- |— SOLO\_HK\_RPW-LFR\_V01.skt
- |— SOLO\_HK\_RPW-PDU\_V01.skt
- |— SOLO\_HK\_RPW-TDS\_V01.skt
- |— SOLO\_HK\_RPW-THR\_V01.skt



## RPW Data Products

Ref: ROC-PRO-DAT-NTT-00006-LES

Issue: 01

Revision: 01

Date: 17/11/2017

- 37 / 40 -

|— SOLO\_L1R\_RPW-LFR-SBM1-CWF-B\_V01.skt  
|— SOLO\_L1R\_RPW-LFR-SBM1-CWF-E\_V01.skt  
|— SOLO\_L1R\_RPW-LFR-SBM2-CWF-B\_V01.skt  
|— SOLO\_L1R\_RPW-LFR-SBM2-CWF-E\_V01.skt  
|— SOLO\_L1R\_RPW-LFR-SURV-CWF-B\_V01.skt  
|— SOLO\_L1R\_RPW-LFR-SURV-CWF-E\_V01.skt  
|— SOLO\_L1R\_RPW-LFR-SURV-SWF-B\_V01.skt  
|— SOLO\_L1R\_RPW-LFR-SURV-SWF-E\_V01.skt  
|— SOLO\_L1R\_RPW-TDS-LFM-CWF-B\_V01.skt  
|— SOLO\_L1R\_RPW-TDS-LFM-CWF-E\_V01.skt  
|— SOLO\_L1R\_RPW-TDS-LFM-RSWF-B\_V01.skt  
|— SOLO\_L1R\_RPW-TDS-LFM-RSWF-E\_V01.skt  
|— SOLO\_L1R\_RPW-TDS-SBM1-RSWF-B\_V01.skt  
|— SOLO\_L1R\_RPW-TDS-SBM1-RSWF-E\_V01.skt  
|— SOLO\_L1R\_RPW-TDS-SBM2-TSWF-B\_V01.skt  
|— SOLO\_L1R\_RPW-TDS-SBM2-TSWF-E\_V01.skt  
|— SOLO\_L1R\_RPW-TDS-SURV-RSWF-B\_V01.skt  
|— SOLO\_L1R\_RPW-TDS-SURV-RSWF-E\_V01.skt  
|— SOLO\_L1R\_RPW-TDS-SURV-TSWF-B\_V01.skt  
|— SOLO\_L1R\_RPW-TDS-SURV-TSWF-E\_V01.skt  
|— SOLO\_L1\_RPW-BIA-SWEEP\_V01.skt  
|— SOLO\_L1\_RPW-HFR-SURV\_V01.skt  
|— SOLO\_L1\_RPW-LFR-SBM1-BP1\_V01.skt  
|— SOLO\_L1\_RPW-LFR-SBM1-BP2\_V01.skt  
|— SOLO\_L1\_RPW-LFR-SBM1-CWF\_V01.skt  
|— SOLO\_L1\_RPW-LFR-SBM2-BP1\_V01.skt  
|— SOLO\_L1\_RPW-LFR-SBM2-BP2\_V01.skt  
|— SOLO\_L1\_RPW-LFR-SBM2-CWF\_V01.skt  
|— SOLO\_L1\_RPW-LFR-SURV-ASM\_V01.skt  
|— SOLO\_L1\_RPW-LFR-SURV-BP1\_V01.skt  
|— SOLO\_L1\_RPW-LFR-SURV-BP2\_V01.skt  
|— SOLO\_L1\_RPW-LFR-SURV-CWF\_V01.skt  
|— SOLO\_L1\_RPW-LFR-SURV-SWF\_V01.skt  
|— SOLO\_L1\_RPW-TDS-LFM-CWF\_V01.skt



## RPW Data Products

Ref: ROC-PRO-DAT-NTT-00006-LES

Issue: 01

Revision: 01

Date: 17/11/2017

- 38 / 40 -

|— SOLO\_L1\_RPW-TDS-LFM-PSD\_V01.skt  
|— SOLO\_L1\_RPW-TDS-LFM-RSWF\_V01.skt  
|— SOLO\_L1\_RPW-TDS-LFM-SM\_V01.skt  
|— SOLO\_L1\_RPW-TDS-SBM1-RSWF\_V01.skt  
|— SOLO\_L1\_RPW-TDS-SBM2-TSWF\_V01.skt  
|— SOLO\_L1\_RPW-TDS-SURV-HIST1D\_V01.skt  
|— SOLO\_L1\_RPW-TDS-SURV-HIST2D\_V01.skt  
|— SOLO\_L1\_RPW-TDS-SURV-MAMP\_V01.skt  
|— SOLO\_L1\_RPW-TDS-SURV-RSWF\_V01.skt  
|— SOLO\_L1\_RPW-TDS-SURV-STAT\_V01.skt  
|— SOLO\_L1\_RPW-TDS-SURV-TSWF\_V01.skt  
|— SOLO\_L1\_RPW-TNR-SURV\_V01.skt  
|— SOLO\_L2\_RPW-LFR-SBM1-BP1\_V01.skt  
|— SOLO\_L2\_RPW-LFR-SBM1-BP2\_V01.skt  
|— SOLO\_L2\_RPW-LFR-SBM1-CWF-B\_V01.skt  
|— SOLO\_L2\_RPW-LFR-SBM1-CWF-E\_V01.skt  
|— SOLO\_L2\_RPW-LFR-SBM2-BP1\_V01.skt  
|— SOLO\_L2\_RPW-LFR-SBM2-BP2\_V01.skt  
|— SOLO\_L2\_RPW-LFR-SBM2-CWF-B\_V01.skt  
|— SOLO\_L2\_RPW-LFR-SBM2-CWF-E\_V01.skt  
|— SOLO\_L2\_RPW-LFR-SURV-ASM\_V01.skt  
|— SOLO\_L2\_RPW-LFR-SURV-BP1\_V01.skt  
|— SOLO\_L2\_RPW-LFR-SURV-BP2\_V01.skt  
|— SOLO\_L2\_RPW-LFR-SURV-CWF-B\_V01.skt  
|— SOLO\_L2\_RPW-LFR-SURV-CWF-E\_V01.skt  
|— SOLO\_L2\_RPW-LFR-SURV-SWF-B\_V01.skt  
|— SOLO\_L2\_RPW-LFR-SURV-SWF-E\_V01.skt  
|— SOLO\_L2\_RPW-TDS-LFM-CWF-B\_V01.skt  
|— SOLO\_L2\_RPW-TDS-LFM-CWF-E\_V01.skt  
|— SOLO\_L2\_RPW-TDS-LFM-RSWF-B\_V01.skt  
|— SOLO\_L2\_RPW-TDS-LFM-RSWF-E\_V01.skt  
|— SOLO\_L2\_RPW-TDS-SBM1-RSWF-B\_V01.skt  
|— SOLO\_L2\_RPW-TDS-SBM2-TSWF-B\_V01.skt  
|— SOLO\_L2\_RPW-TDS-SURV-RSWF-B\_V01.skt





# RPW Data Products

Ref: ROC-PRO-DAT-NTT-00006-LES

Issue: 01

Revision: 01

Date: 17/11/2017

- 40 / 40 -

## 7 DISTRIBUTION LIST

<p style="text-align: center;"><b>LISTS</b></p> <p>See Contents lists in “Baghera Web”: Project’s informations / Project’s actors / RPW_actors.xls and tab with the name of the list or NAMES below</p>	Tech_LESIA
	Tech_MEB
	Tech_RPW
	[Lead-]Cols
	Science-Cols

### INTERNAL

LESIA CNRS		

LESIA CNRS		

### EXTERNAL (To modify if necessary)

CNES	C. FIACHETTI
	C. LAFFAYE
	R.LLORCA-CEJUDO
	E.LOURME
	M-O. MARCHE
	E.GUILHEM
	J.PANH
	B.PONTET
IRFU	L. BYLANDER
	C.CULLY
	A.ERIKSSON
	SE.JANSSON
	A.VAIVADS
LPC2E	P. FERGEAU
	G. JANNET
	T.DUDOK de WIT
	M. KRETZSCHMAR
	V. KRASNOSELSKIKH
SSL	S.BALE

AsI/CSRC	J.BRINEK
	P.HELLINGER
	D.HERCIK
	P.TRAVNICEK
IAP	J.BASE
	J. CHUM
	I. KOLMASOVA
	O.SANTOLIK
	J. SOUCEK
IWF	L.UHLIR
	G.LAKY
	T.OSWALD
	H. OTTACHER
	H. RUCKER
	M.SAMPL
LPP	M. STELLER
	T.CHUST
	A. JEANDET
	P.LEROY
	M.MORLOT